

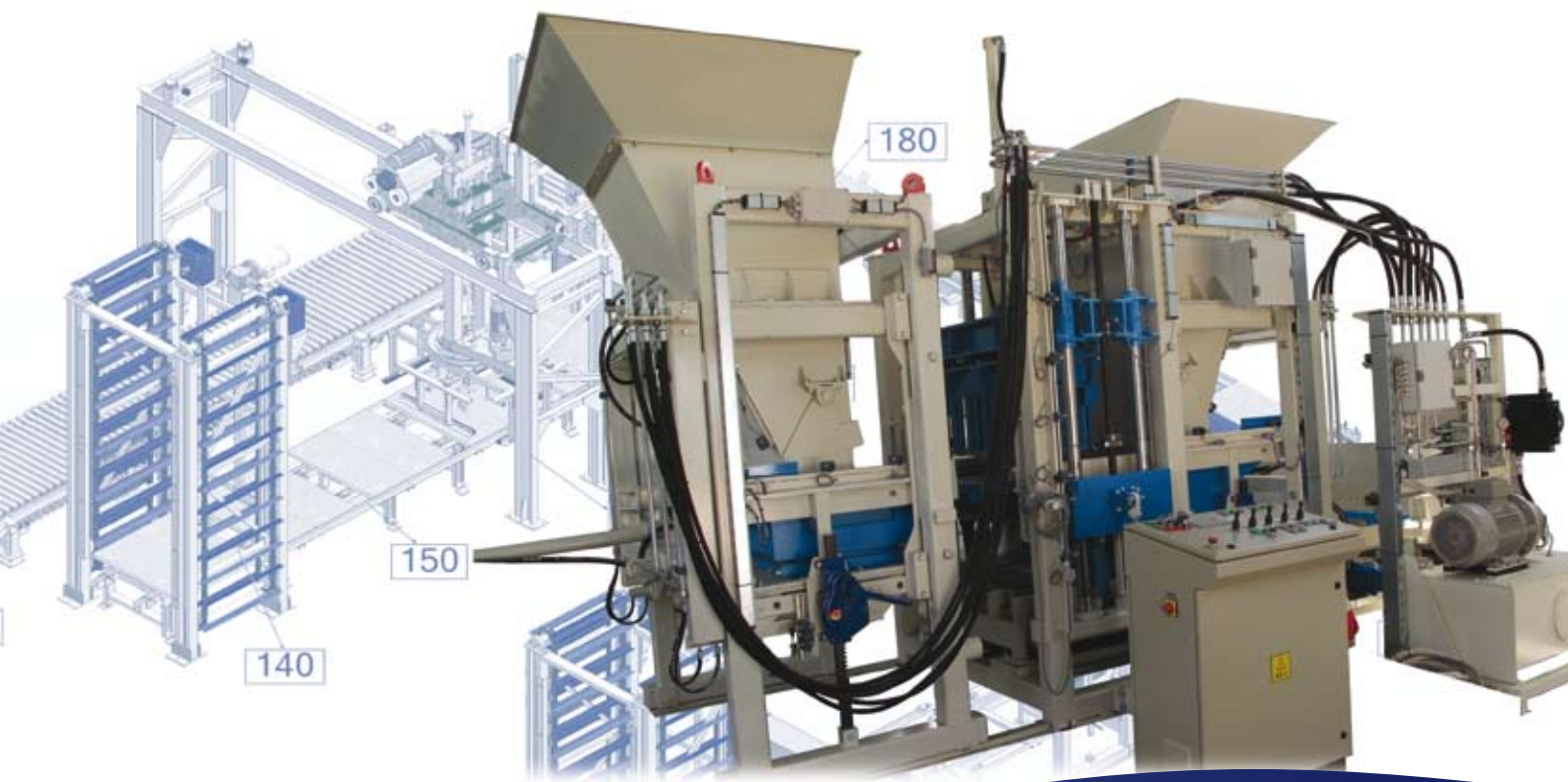

RHC 500 & RHC 400



**CONCRETE
PRODUCTS MACHINE**



CONTEC

• **RELIABLE - HEAVY DUTY CONSTRUCTION - LOW MAINTENANCE**



With RHC 500 and RHC 400 concrete products machines we provide excellent medium level entry solution, and also long term solution for many customers.

These machines combine durable, heavy duty construction with possibility for assembly various concrete product lines - from simple to fully automatized.

Production of high quality concrete products is offered with RHC series of machines: concrete paving stones, hollow blocks, solid blocks, insulated blocks, curbstones, gardening blocks etc...



Tamper head bridge



Guide columns and height control



Pallet magazine with speed regulation

• SYNCHROTRONIC VIBRATION SYSTEM

RHC machines are working with hi efficiency vibration system named SYNCHROTRONIC VIBRATION.

Vibrators driven with frequency regulators, enables operator to adjust the frequency during machine cycle providing hi speed mould feeling and final product compaction.

Rigid mechanical structure of vibrating table and vibrators ensure hi durability and low maintenance.

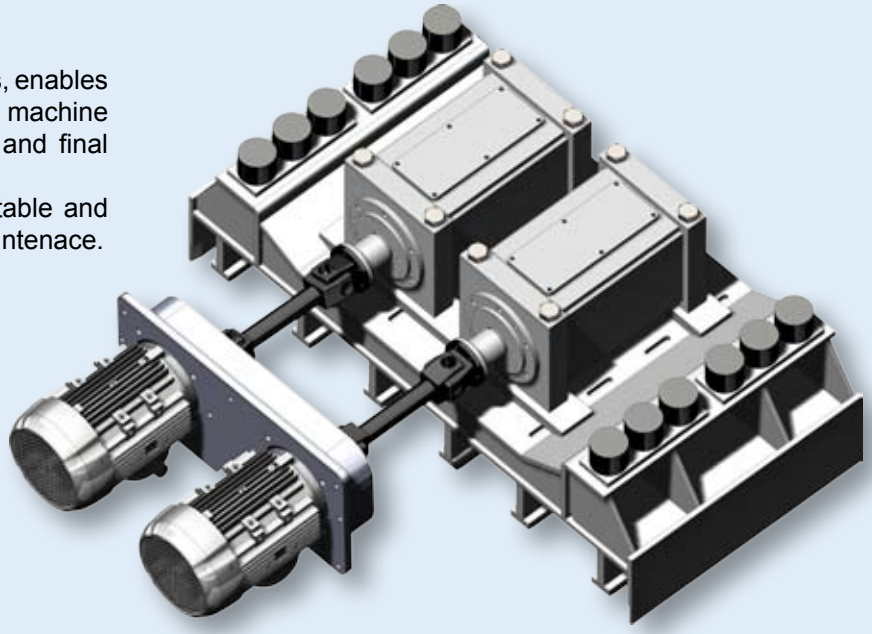

Technical features

RHC 500:

- Production board size... 1400x700 mm
- Production area:..... 1300x650 mm
- Production height:..... 25 - 300 mm

RHC 400:

- Production board size... 1200x550 mm or max 1350x550 mm for pallets with legs/support
- Production area:..... 1100x500
- Production height:..... 25 - 300 mm

MACHINE	PRODUCT	Size	Face mix	Number of products/mould	Cycle time/sec	Production capacity 8h/100%
RHC 500	Paving stone	10x20x6 cm	without	30	17	1016 m2
	Paving stone	10x20x6 cm	with	30	20	864 m2
	Hollow block	20x20x40 cm		9	20	12960 pieces
RHC 400	Paving stone	10x20x6 cm	without	20	15	760 m2
	Paving stone	10x20x6 cm	with	20	18	570 m2
	Hollow block	20x20x40 cm		5	18	8000 pieces

Exact output depend on concrete mix design, machine settings, wall thickness etc. Usual output should be calculated by 85 - 90% of maximum data.

• LAYOUT SAMPLES

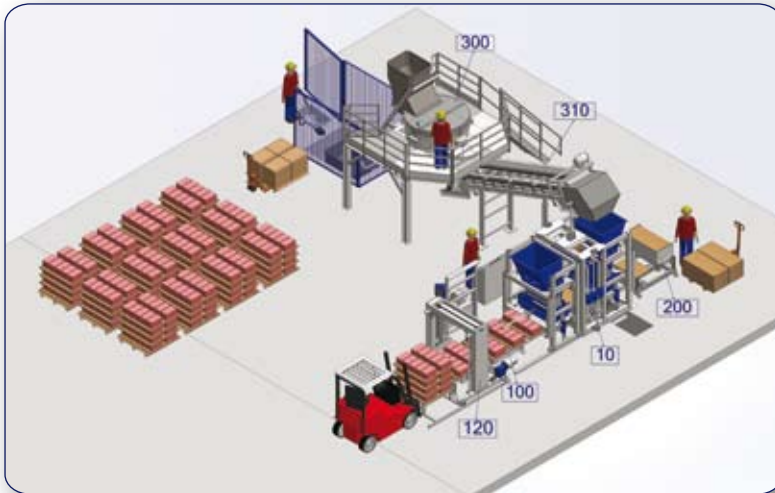

Basic Line

- 10 – Machine RHC 500 / RHC 400
- 100 – Transport of finished concrete elements of the machine
- 120 – Stacker device
- 200 – Pallet magazine
- 300 – Mixer TCM 500/350
- 310 – Transport of material from mixer to machine

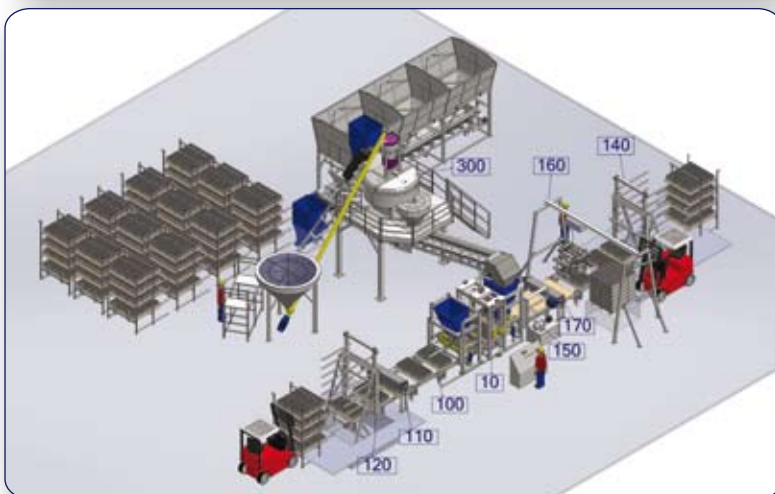

One line rack system

- 10 – Machine RHC 500 / RHC 400
- 100 – Transport of finished concrete blocks of the machine
- 110 – Device for cleaning product surface
- 120 – Elevator
- 140 – Lowerator
- 150 – Transport of pallets from lowerator to cubing position
- 160 – Pneumatic cuber
- 170 – Device for cleaning the working pallets
- 300 – Batching plant

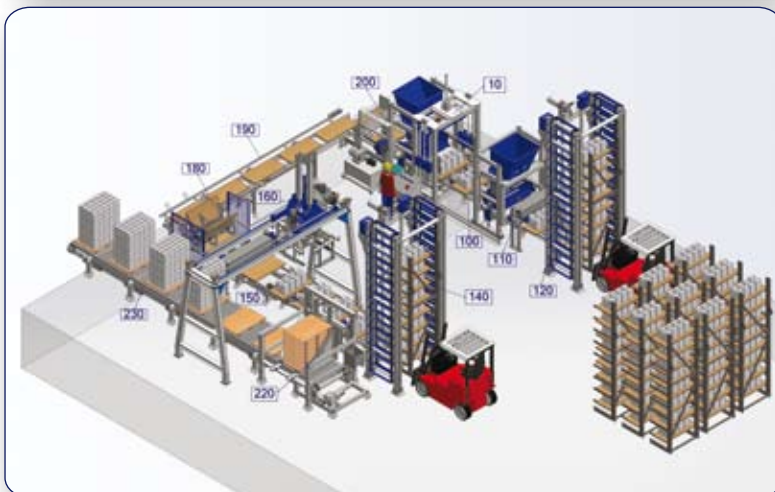

Closed line rack system

- 10 – Machine RHC 500 / RHC 400
- 100 – Transport of finished concrete blocks of the machine
- 110 – Device for cleaning product surface
- 120 – Elevator
- 140 – Lowerator
- 150 – Transport of pallets from lowerator to cubing position
- 160 – Cuber
- 180 – Device for rotating pallets
- 190 – Pallet cross carrier
- 200 – Pallet magazine
- 220 – The equipment for storage and descending of transport pallets
- 230 – Slat conveyor